

powermate plus

MODEL 4283

DESCRIPTION

General

Jerrold Model 4283 is an antenna-signal amplifier system consisting of a three-transistor pre-amplifier, Model 283 and a remote a.c. power supply, Model 302. The system is designed for improving reception of both YHF and UHF TV channels and the f-m band in fringe and semi-fringe areas.

Model 283

The pre-amplifier employs a two-stage UHF amplifier circuit board and a single-stage VHF amplifier circuit board, which also contains the common d.c. power supply. A lightning and static surge protector for the input terminals is also provided on the YHF circuit board. An f-m trap is provided which is tuned by indicator slug for eliminating a strong, interfering signal in the f-m band. The broad-band input and output circuits are 300/75-ohm hybrid balun transformers. Both input and output terminals are 300-ohm screw and crown-washer type, designed for quick, no-strip connection of either standard foam all-channel twin-lead.

Model 283 is contained in an attractive, weather-proof cyclac housing designed for mounting on any flat surface, or for boom or mast mounting with the accessories supplied.

Model 302

The a.c. power supply accepts 117V a.c. line power and furnishes approximately 23V rms to the rectifier of the pre-amplifier via the ANTENNA terminals of the power supply, the down-lead and the POWER SUPPLY terminals of the pre-amplifier.

Model 302 has two external shorting links which permit selecting either the SINGLE SET output, or L outputs for two TV/FM receivers, SET 1 and SET 2. These outputs are established by a special, hybrid splitting transformer (pat. pend.). Static drains are provided for preventing static build-up on the down-lead.

Model 302 is housed in a modern, metal and cyclac case designed for mounting on any flat surface indoors.

SPECIFICATIONS

FREQUENCY RANGE	54 to 216 MHz	470 to 750 MHz
GAIN (Average)	SINGLE SET	VHF 13.5dB UHF 11.5dB
	TWO SETS	VHF 10dB UHF 8dB
FLATNESS (Max. P/V)	VHF 1.5dB	UHF 2.5dB
NOISE FIGURE (Average)	VHF 7dB	UHF 11.5dB
MAX. RECOMMENDED INPUT LEVEL.	VHF 16,000uV per Channel for 4 Channels	
	UHF 15,000uV per Channel for 3 Channels	
DISTORTION	0.5% (-46dB) Cross Modulation at Max. Input	
F-M TRAP ATTENUATION	11dB, 10 MHz B-W, Adjustable 88 to 108 MHz	
IMPEDANCES	300-ohms, all-terminals	
POWER REQUIREMENT	117V a.c., 60 Hz, 65mA, 8.2W	

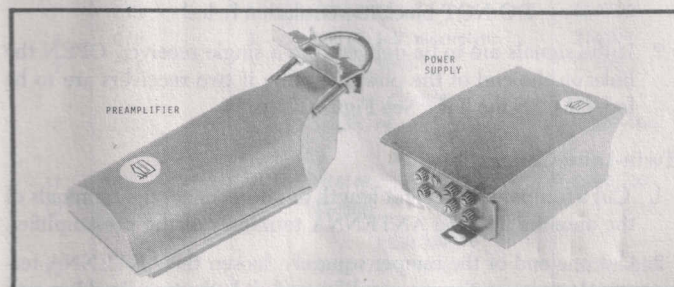

FIG. 1 MODEL 4283 ALL-CHANNEL POWERMATE PLUS

INSTALLATION

General

For maximum benefit from the signal strength available at the antenna and for minimum pickup of undesired signals, it is recommended that the Model 283 be mounted as near to the antenna terminals as practical and that the jumper between the antenna and the pre-amplifier be kept as short as possible.

Accessories Supplied

- 1-"U" bolt
- 2-Self-locking hex-nuts
- 2-#10 x 3/8 inch wood-screws
- 2-#6 x 1/2 inch wood-screws

Materials and Tools Required

1. Sufficient all-channel, 300-ohm twin-lead for interconnecting the antenna, the pre-amplifier, the a.c. power supply and the TV receiver (s).
2. Sufficient 7-inch insulated stand-offs for securing the down-lead.
3. A 7/16 inch nut-driver or wrench.
4. A common, cabinet screwdriver or 1/4 inch nut-driver.
5. A pair of wire-cutters.

Boom Mounting the Pre-Amplifier

1. Assemble the top bracket of the Model 283 to the antenna boom as shown in Figure 2, using the "U" bolt and self-locking hex-nuts supplied.
2. Wrench-tighten the hex-nuts firmly.

Mast Mounting the Pre-Amplifier

1. Assemble the rear bracket of the Model 283 to the antenna mast as shown in Figure 3, using the "U" bolt and self-locking hex-nuts supplied.
2. Wrench-tighten the hex-nuts firmly.

Surface Mounting the Pre-Amplifier

1. Position the Model 283 against any vertical flat surface using the holes in the rear bracket, or on a horizontal flat surface, such as under eaves, using the holes in the top bracket. See Figures 4 and 5.
2. Secure the pre-amplifier with the two #10 x 3/4 inch wood-screws supplied.

Installing the Power Supply

1. Using the two #6 x 0! inch wood-screws supplied, mount the Model 302 on any flat surface near the TV receiver and near a 117V a.c. outlet.

CAUTION: When the unit is mounted on the back of a TV receiver, DO NOT block its ventilation holes.

2. If the signals are to be delivered to a single receiver, OPEN the links on the end of the power supply; if two receivers are to be fed, CLOSE the links. See Figure 6.

Twin-Lead Connections

1. Cut a jumper of sufficient length to interconnect the terminals of the antenna and the ANTENNA terminals of the pre-amplifier.
2. Cut one end of the jumper squarely, loosen the ANTENNA terminal screws on the pre-amplifier and slide the twin-lead beneath the crown-washer serrations. See Figure 7.
3. Tighten the terminal screws so that the serrations pierce the insulation and contact the conductors.
4. Connect the opposite end of the jumper to the 300-ohm terminals of the antenna, then form a drip-loop and secure the jumper with a stand-off in order to prevent wind-whip and consequent picture flutter.

NOTE: Disconnect any impedance matching device from the antenna terminals.

5. Cut a down-lead of sufficient length to interconnect the pre-amplifier and the power supply; cut the ends off squarely.
6. Loosen the POWER SUPPLY terminal screws on the pre-amplifier and connect the twin-lead as done under steps 2 and 3 above.
7. Run the down-lead to the desired point-of-entry, twisting ribbon-type lead about one turn every three feet for minimizing interference pickup and wind-whip.
8. Secure the down-lead with an appropriate stand-offs and form a drip-loop at the point-of-entry.
9. Run the remaining down-lead into the building and to the a.c. power supply, then connect the twin-lead to the ANTENNA screw and crown-washer terminals as done in steps 2 and 3 above.
10. Refer to Figure 6, then cut one or two jumpers as required for connecting the Model 302 to either one or two TV/F-I receivers, as determined in step 2 under INSTALLING THE POWER SUPPLY.
11. Connect a single jumper between the SINGLE SET terminal on the a.c. power supply and the TV receiver; or for two sets, connect the two jumpers between the SET 1 and SET 2 terminals on the power supply and the two receivers; in either case connect the twin-lead as done in steps 2 and 3 above.
12. Plug the line-cord into a 117V a.c. outlet; the Model 4283 is now operational.

Tuning the F-M Trap

1. Tune the TV receiver to the channel on which f-m interference is strongest.
2. Using a non-conductive "Allen" hex-tool, turn the inductor slug, accessible through the hole in the bottom panel of the pre-amplifier, CLOCKWISE until f-m interference is minimized.

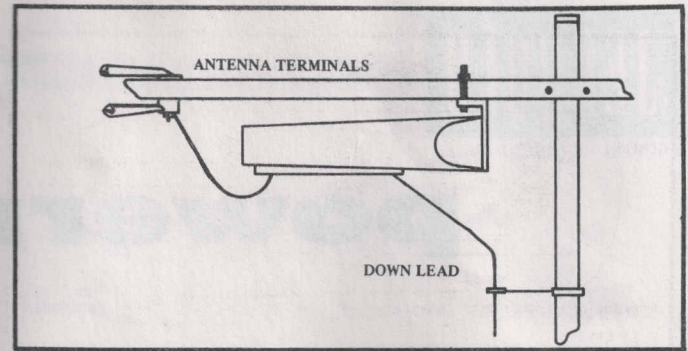

FIGURE 2 MODEL 4283 MOUNTED ON ANTENNA BOOM

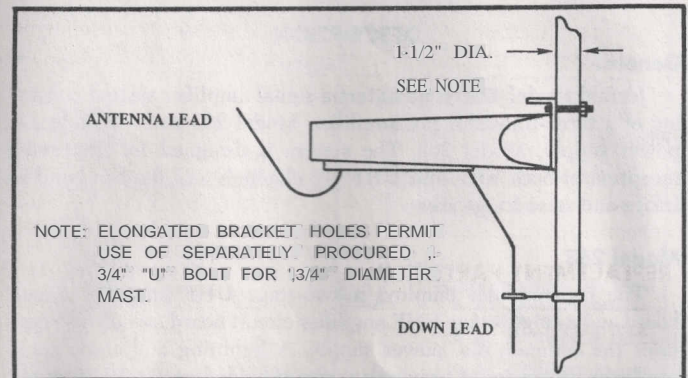

FIGURE 3 MODEL 4283 MOUNTED ON ANTENNA MAST

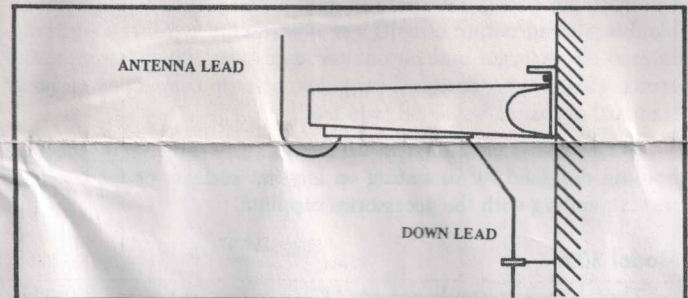

FIGURE 4 MODEL 4283 MOUNTED ON A WALL

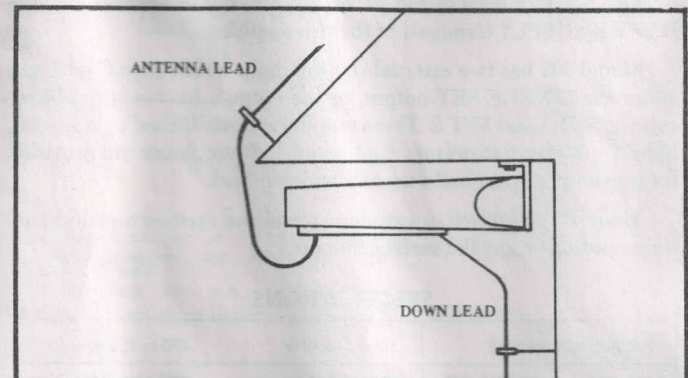

FIGURE 5 MODEL 4283 MOUNTED UNDER EAVES

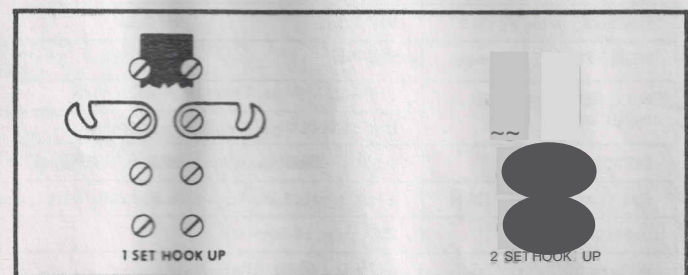

FIGURE 6 MODEL 302 TWIN-LEAD CONNECTION

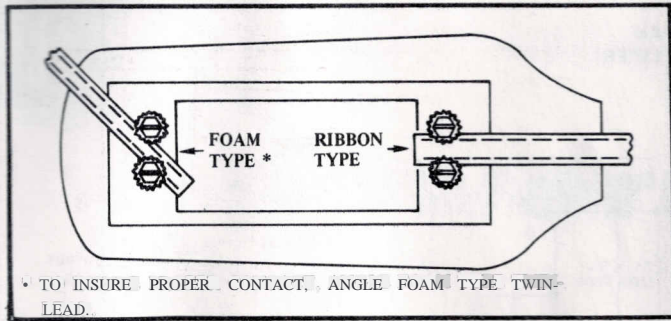

FIGURE 7 CONNECTING THE TWINLEAD

NOTE: Alternatively, where a field strength meter is available, the interfering signal level may be observed while turning the slug CLOCKWISE for a null meter indication.

Maintenance

In the event servicing becomes necessary, it must be done by a skilled technician familiar with solid-state circuitry. For his benefit a schematic circuit diagram and a replacement parts list are provided.

REPLACEMENT PARTS LIST

MODEL 4283

ASSEMBLY: MODEL 302 POWER SUPPLY		REF. DWG. NO.: 21556		
Item	Schematic Designation	Qty.	Description	Jerrold Part No.
CAPACITORS				
1	C1	1	68 pF	122-003
2	C2,3	2	1000 pF	123-115
CHOKES				
3	L1,2	2	r-f	21518-001
POWER CORD				
4	P1	1	6ft.	159-13-1
RESISTORS				
5	R1,2	2	1M, 1/2W, 20%	112-743
TRANSFORMER				
6	T1	1	Power	141-233

REPLACEMENT PARTS LIST

MODEL 4283

ASSEMBLY: MODEL 283 PRE-AMPLIFIER		REF. DWG. NO.: 21555		
Item	Schematic Designation	Qty.	Description	Jerrold Part No.
CAPACITORS				
1	C1, 3, 7,10, 12,22	6	3.3 pF, ± 0.25 pF	21660-1
2	C2	1	4.7 pF, ± 0.25 pF	21660-2
3	C4, 6, 9,11, 17,19,20,24	8	0.021-μF, +20% -80%	124-065
4	C5,8	2	56 pF, 10%	21491-1
5	C13,21	2	7.5 pF, 5%	21489-3
6	C14,16	2	30 pF, 5%	21489-5
7	C15	1	120 pF, 10%	21491-3
8	C18	1	250 μF, 16V, electrolytic	21659-1
9	C17	1	100pF,10%	21491-2
CHOKE				
10	L13	1	2.31-μH, r-f	157-006
DIODES				
11	CR1,2	2	IN4148	21401-001
12	CR3	1	Rectifier	137-718
RESISTORS				
13	R1, 4, 7	3	2.2k, 1/4W, 10%	21357-029
14	R2, 5, 8	3	7.5k, 1/4W, 5%	21358-070
15	R3,6	2	680-ohms, 1/4W, 10%	21357-023
16	R9	1	1.5k, 1/4W, 10%	21357-027
17	R10	1	10-ohms, 1/4W, 10%	21357-001
18	R11	1	330-ohms, 1/4W, 10%	21357-019
19	R12	1	1.5k, 1/2W, 10%	21360-027
20	R13	1	180-ohms, 1/2W, 10%	21360-016
TRANSISTORS				
21	Q1,2,3	3	A2297	130-220

SCHEMATIC DIAGRAM
POWERMATE PREAMPLIFIER
MODEL 283

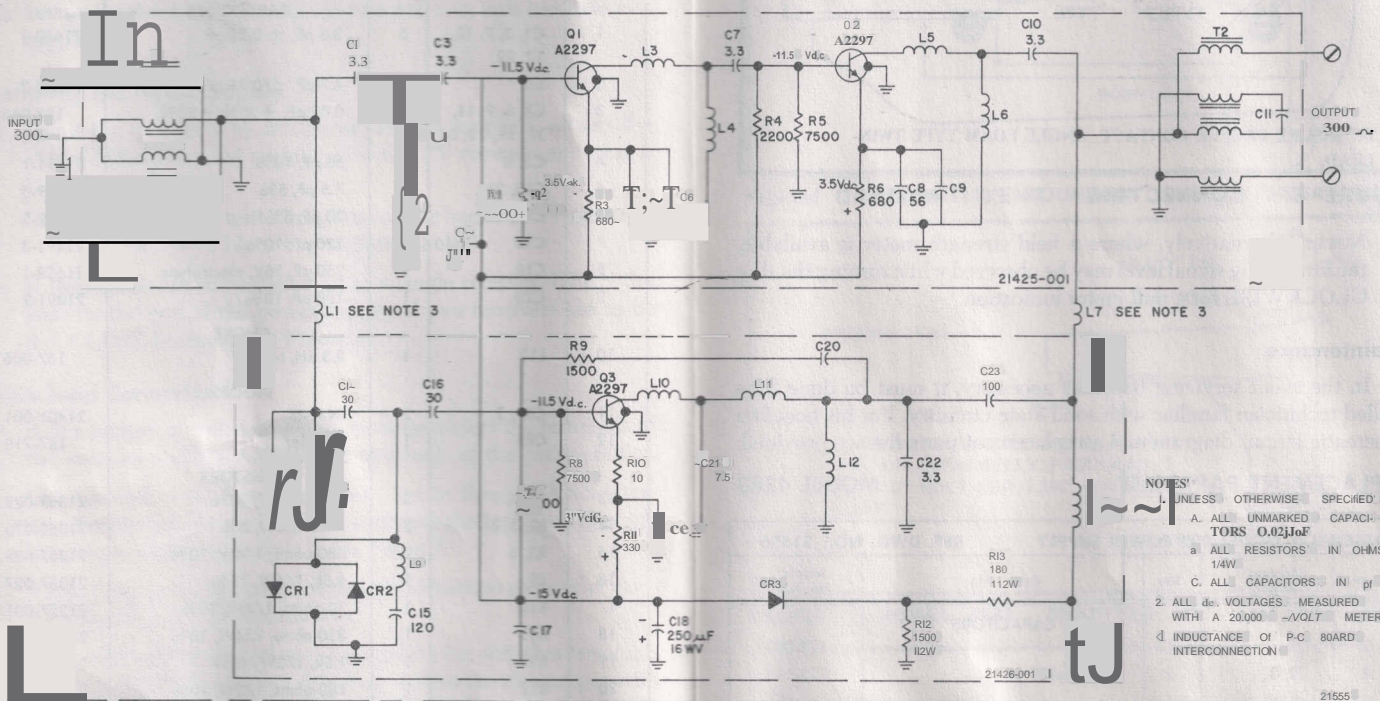

SCHEMATIC DIAGRAM
POWER SUPPLY
MODEL 302

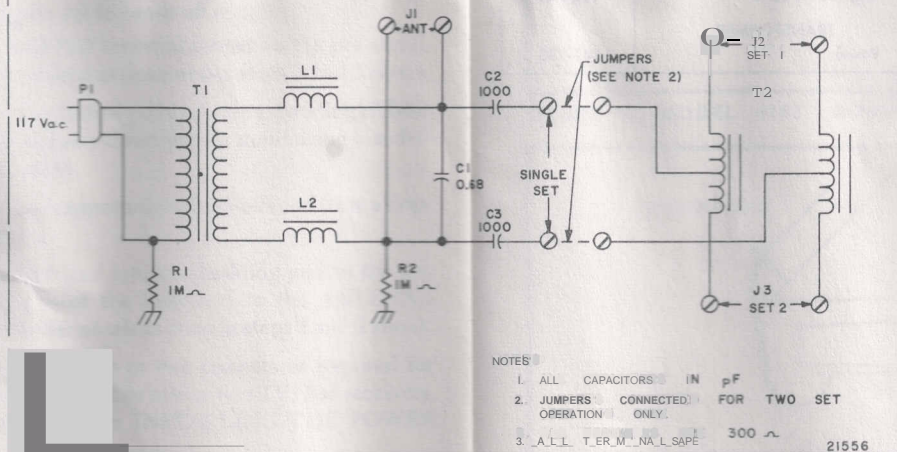

ALL DATA SUBJECT TO CHANGE WITHOUT NOTICE

WARRANTY

Each unit of Jerrold Equipment is warranted for 90 days against original factory imperfections in material and workmanship.

In the event any unit of equipment should fail in service during this period, pack the complete defective unit carefully, attach a letter stating the reasons the unit was believed to be defective, and return it to our Service Department, Jerrold Electronics Corp., New Berlin, N.Y., 13411, prepaying transportation charges. It shall be repaired or replaced at no charge.

Such service or repairs as may be necessary as the result of abuse or accident are not included in the warranty. In the event of any service breakdowns during the warranty period, this unit may be repaired at a nominal charge.

JERROLD ELECTRONICS CORPORATION
DISTRIBUTOR SALES DIVISION
PHILADELPHIA, PA. 19105

THE NATION'S FOREMOST
MANUFACTURER AND SUPPLIER
OF TELEVISION DISTRIBUTION SYSTEMS

EM 10/68

435-409

Printed in U.S.A.

30211-001